

The Effect of Formal Specifications and Working Conditions on the Resistance and Vibration of the NACA 4415 Aircraft Wing Model

Ali S. Jaafar

Department of Mechanical Engineering, University of Baghdad, Iraq
ali.sadiq2303m@coeng.uobaghdad.edu.iq (corresponding author)

Nassear R. Hmoad

Department of Aeronautical Engineering, University of Baghdad, Iraq
nassear-machine@coeng.uobaghdad.edu.iq

Received: 28 July 2024 | Revised: 2 September 2024 | Accepted: 19 September 2024

Licensed under a CC-BY 4.0 license | Copyright (c) by the authors | DOI: <https://doi.org/10.48084/etasr.8547>

ABSTRACT

Due to their role in airplane performance, wings receive much attention considering their strength enhancement and vibration reduction. Many parameters have been considered and various materials have been used to achieve these objectives. The current work studies numerically the effect of the number of ribs and the angle of attack, on strength, response, and natural frequency at various speed values, using the ANSYS 2021 R1 solver. The adopting material is the AA 7075 T6 aluminum alloy with 71.7 GPa modulus of elasticity, 503 MPa tensile yield strength, 2810 kg/m³ density, and 0.33 Poisson's ratio. Results show that when the velocity is increased by 30%, a corresponding elevation of 11% can be seen in vibrational distortion. Regarding the angle of attack, it was noted that doubling its value leads to a 28% reduction in vibration-induced deformation. This phenomenon occurs as a result of the alteration in the pressure distribution on the wing caused by the change in the angle of attack.

Keywords-unmanned aerial vehicles; angle of attack; ribs; vibration; frequency response

I. INTRODUCTION

A. Background

Unmanned Aerial Vehicles (UAVs) have become rather popular in many different fields. When compared to traditional manned aircrafts, UAVs offer clear advantages, such as improved flexibility, lower cost, and the capacity to access far-off and difficult surroundings. From airborne surveillance to infrastructure inspection to precision farming to search and rescue missions, UAVs have found use in many fields [1].

B. Aim of this Study

This research aims to increase aircraft wing strength and lower wing vibration by means of a study on the impacts of the angle of attack (AOA) and the speed of aircraft.

C. Wing Geometry

1) Definition

The wings of an aircraft are obviously among their most important parts. Mostly, the wings generate the aerodynamic lift to overcome the weight of the aircraft. They also include movable parts like ailerons, flaps, spoilers, and trim tabs, that

provide extra aerodynamic forces that control the aircraft over its flight. Wings are geometrically characterized by their span (the distance between the wing tips), planform (the shape of the wing when viewed from above), twist distribution (the angle at which the wing is pitched), and cross-section (the shape of the wing's airfoil or profile). The primary objective of aerodynamic design is to optimize the lift-to-drag ratio. Therefore, the shape of a wing must be constructed to achieve high aerodynamic efficiency in generating lift while minimizing drag. However, several aerodynamic factors will consistently impact the wing design's performance during low-speed flight, high angle of attack, and stalling [2]. In addition to the aforementioned factors, the wing structure must possess sufficient strength and rigidity to withstand the aerodynamic, weight, inertial, and other loads that act upon it. Hence, the wing must be meticulously engineered to save weight while yet withstanding all pressures and adhering to structural load requirements.

2) Aerodynamics

Design and research of aircraft wings consist one of the primary applications of the discipline of fluid mechanics sometimes referred to as aerodynamics. Finding, in theory, the

properties of the airflow around any moving object by solving the Navarete-Stokes equations of fluid dynamics is possible, but, except from fundamental geometries, these equations are famously difficult to solve and simpler equations are used [3]. If a wing is to provide lift, it must be oriented at an appropriate AoA. This causes the wing to deflect the wind downward as it flows past it. Since the air flows in the direction of the force applied by the wing, it must thus likewise exert an equal and opposite force on the wing. Enhancing aerodynamic efficiency and minimizing drag is an effective method for decreasing carbon emissions and fuel consumption [4].

D. Aircraft Wing Vibration

Vibration, in mechanical systems or structures, is the fast back-and-forth motion about an equilibrium point. Several elements, including machinery operation outside forces, including resonance and wind, can bring it on. Unchecked or too strong vibration can cause structural damage, discomfort, and possibly mechanical component failure. In aircraft engineering design, both vibration and fatigue are important factors to guarantee the safety, dependability, and lifetime of mechanical systems and structures [5].

E. Modes of Material Failure

Material wear or deformation inconsistent with vibration can result from vibration failure. For instance, over time, periodic vibrations can cause materials to crack or distort, particularly in metal buildings or components under cyclic loads. These are some typical forms of failure; thus, operating conditions, material type, and environmental conditions might affect failure.

F. Tests of Failure

By controlled vibrations, a material or component is subjected to replicate real-world conditions and thereby allowing us to detect possible places of failure. This test evaluates the resistance to fatigue failure brought on by vibration-induced stress as well as the material's capacity to tolerate dynamic loading. Engineers can ascertain the dependability and longevity of a material in vibrating surroundings, including equipment or aircraft wings, by examining its reaction to vibration. This kind of testing guarantees that components satisfy the criteria of quality and safety and helps to improve product design [6].

G. Material

Aluminum 7075 was considered as the wing material. Thanks to its high zinc content, aluminum 7075 has a strength similar to that of steel. It is easy to machine and has perfect fatigue resistance. It was the common choice for World War II aircrafts and can often be seen in military crafts [7]. Aircraft wing design is entirely dependent on airfoil design or selection. NACA (the predecessor of NASA) created numerous families of airfoils and camber lines in the 1930s [8].

H. Literature Review

Solving aerodynamic equations has a large experimental cost. This is why numerical techniques are favored instead. Authors in [9] digitally calculated the lift and drag forces varying the inlet velocity from 0 to 50 m/s. Authors in [10]

studied low Reynolds number airplane wing aerodynamics at various AoA values. The lift coefficient increases linearly, peaking at 32° (stall angle) and then decreases until 90°. Because AoA affects airfoil drag, laminar flow becomes turbulent. Turbulence increases airflow distance from the airfoil surface, separating lift and drag. Wing performance suffers. In [11], a high-resolution vortex method was utilized to examine 500 Reynolds-number symmetrical airfoil flows. This study examines airfoil thickness and AoA-induced non-linear wake and aerodynamic stresses. The airfoil wake pattern becomes multiperiodic as AoA increases from 0° to 60°. At an AoA of 15°, the stationary phase lift-to-drag ratio is maximum. AoA increases drag, lowering airfoil performance. Thickness affects stationary airfoils, with thinner ones being more hydrodynamic. Trailing edge negative pressure zones expand with AoA due to boundary layer phenomena. In [12], and at all wing section planes (butt planes-BL), the Computational Fluid Dynamics (CFD) results show that the upper surface of the wing has a lower pressure than the bottom surface supporting the lift generation hypothesis. Pre-stressed modal analysis shows how stress, deformation, and vibrational modes are related. When considering the wing structure design frequency, the maximum deformation of 17.164 mm matches the modal frequency of 179.65 Hz. However, the wing structure's fundamental natural frequency is 10.352 Hz, which causes 11.383 mm deformation. An NACA 4415 low-speed wing investigation showed improved lift and lower drag. It advised modest angles of attack for the NACA 4415 airfoil due to flow separation [13]. The 200 mm chord, 4.96 mm leading edge radius, and 450 mm span made the model fascinating. Low-speed open return wind tunnel test section was 0.47 m wide, 0.47 m tall, and 1.27 m long. AoA increases lift coefficient at both considered speeds. The lift coefficient peaked at 1.45° at 15 m/s and 1.40° at 25 m/s. AoA increased drag to 0.15° at 15 m/s and 0.2° at 25 m/s. The wing model's low drag and high lift help airplanes and wind turbine blades. Pressure distribution research in vortices revealed negligible flow separation at low aircraft AoA (-6° to 0°). Flow splits at intermediate levels (3° to 9°) and high angles (12° to 18°).

II. RESULTS AND DISCUSSION

This study presents a methodology for modeling and simulating Computational Fluid Dynamics (CFD) problems on an aircraft wing model using root and tip airfoil sections such as NACA 4415. An investigation of the pressure and velocity distribution on the surface of an aircraft wing is conducted using ANSYS Fluent. We consider the movement of the fluid as the flow of air. The kinematic viscosity is $1.7894 \times 10^{-5} \text{ m}^2/\text{s}$, and the density is 1.225 kg/m^3 . Therefore, the flow properties are chosen to resemble those employed in the experiment. All the properties of the materials mentioned were utilized in the simulations. The design has been constructed with a bottom-up approach style in order to achieve more precise results. The wing is designed by first modeling its internal structural components such as spars and ribs. Then, a bottom-up approach is used to assess the aerodynamic pressure loads on the wing. ANSYS Fluent provides readily accessible pressure and velocity distributions, as well as various additional graphical and animated representations. The pressure distribution contours in the airflow when the applied velocity at

the inlet is 13 m/s (47 km/h). The high-pressure areas show up on the lower surface of the airfoil and at the leading edge, as depicted in Figure 1. The low-pressure area manifests on the top surface of the airfoil. This study is accurate considering lift generation as the theory. Another crucial feature to investigate in the airflow across the airfoil section is velocity, with pressure being inversely proportional to it. Figure 2 exhibits velocity distribution contours in the airflow, with 13 m/s being the velocity applied at the intake. As one can observe, the upper surface of the airfoil shows the high-velocity areas. The lower surface of the airfoil shows a low-velocity zone.

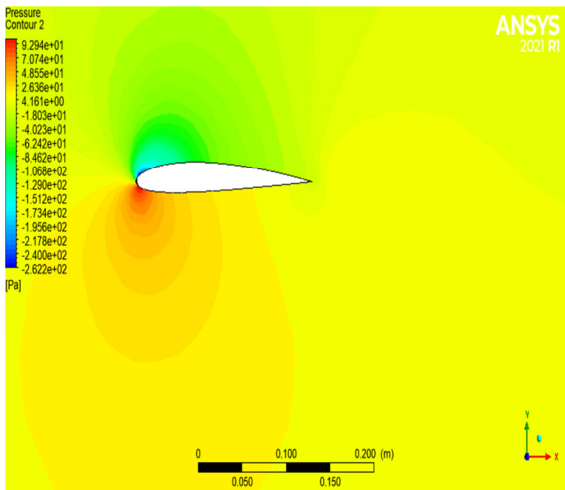

Fig. 1. Pressure distribution at the mid-span of the wing.

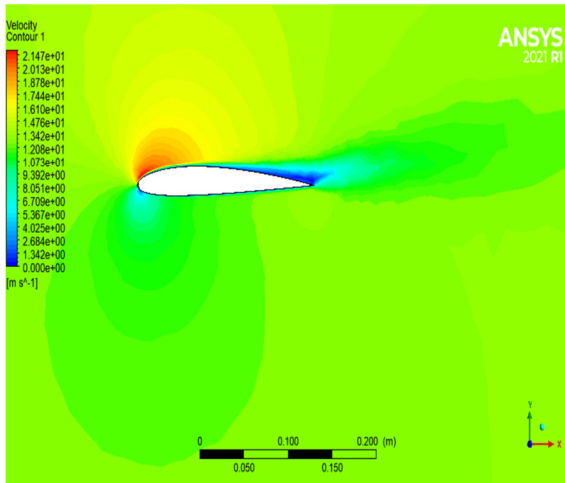

Fig. 2. Velocity distribution at the mid-span of the wing.

I. Analysis of the Aircraft Wing's Structure

This project details the design of an aircraft wing according to NACA criteria. The stresses, deformation, and strains in aircraft wing structure were computed by stress analysis of the wing. Stress was found using ANSYS workbench 2021 utilizing the finite element approach. Pressure loads are used for structural studies on the wing. The adopted material properties (aluminum alloy AA 7075 T6) are 71.7 GPa modulus of elasticity, 503 MPa tensile yield strength, 2810 kg/m³ density, and 0.33 Poisson's ratio.

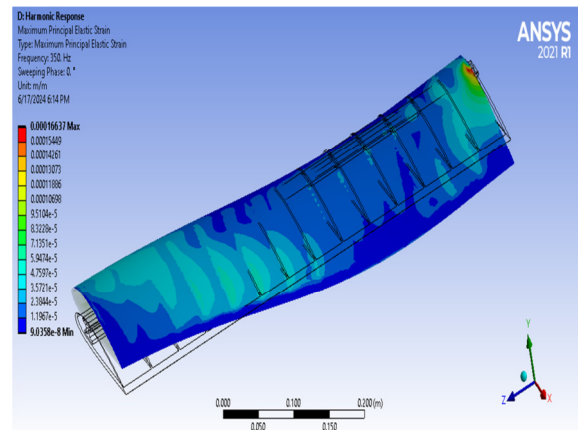

Fig. 3. Maximum principal strain in the wing.

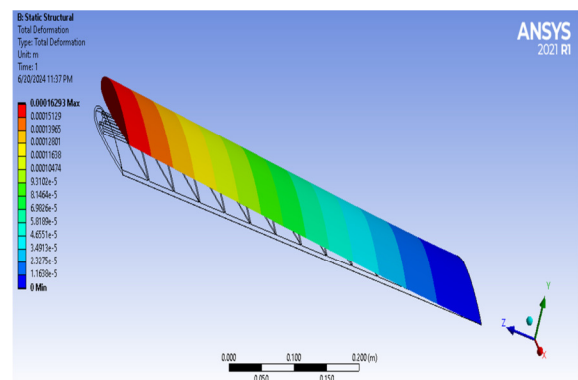

Fig. 4. Total deformation.

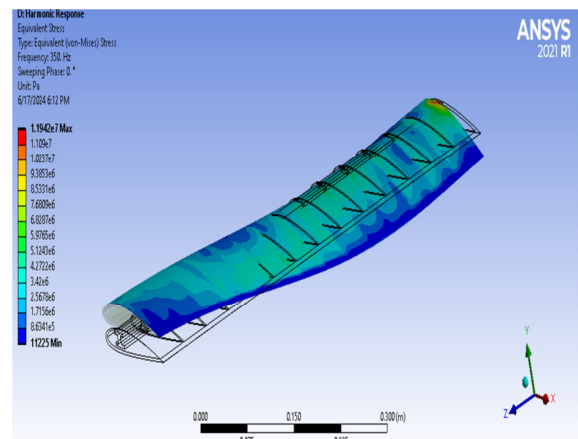

Fig. 5. Equivalent (von Mises) stress in the wing.

Figure 5 displays von Mises or equivalent tensile stress. The material starts to yield when the von Mises stress approaches a critical value. Though the highest stress is created in the root region of the wing, uniform stress distribution is seen throughout it. Under these conditions, the von Mises stress recorded in the wing analysis is 11.942 Mpa, less than the aluminium alloy's yield strength. The structure is safe since the obtained stress from the study is smaller than the structural material's yield strength. Figure 4 depicts the deflection of the wing; pressure load causes the wing to bend upward.

A. Pre-Stressed Modal Analysis

Modal analysis under vibration excitation allows one to investigate the dynamic features of aircraft wing structure. In aircraft wings, the lift force and the load resulting from mounting engines cause vibration. The modal analysis determines the several periods at which the structure will naturally resonate by use of its overall mass and stiffness characteristics. The dynamic analysis consisted of the estimation of natural frequencies and mode shapes and deformation computations resulting from inertial loads at higher load factors. Figures 6-12 and Table I demonstrate the modes forms, deformation, and related frequencies.

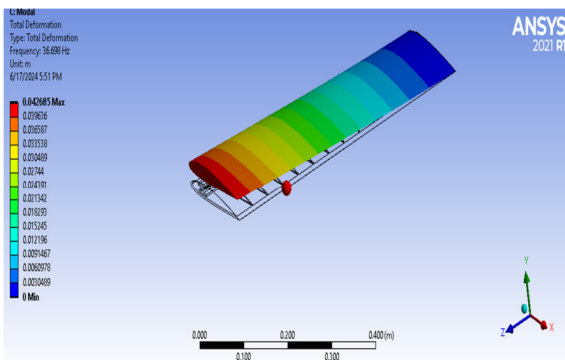

Fig. 6. Wing deformation at mode 1.

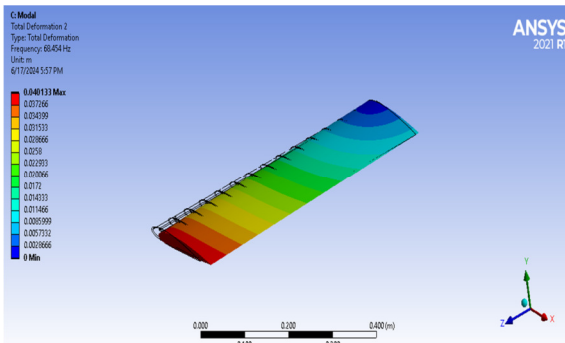

Fig. 7. Wing deformation at mode 2.

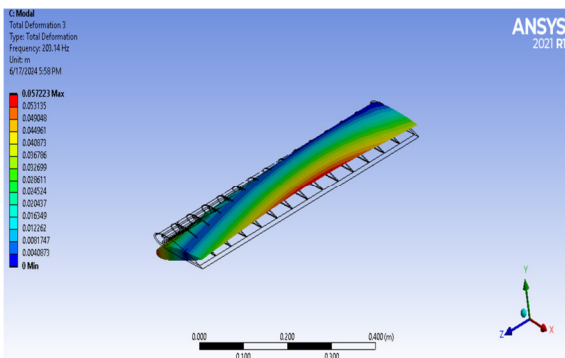

Fig. 8. Wing deformation at mode 3.

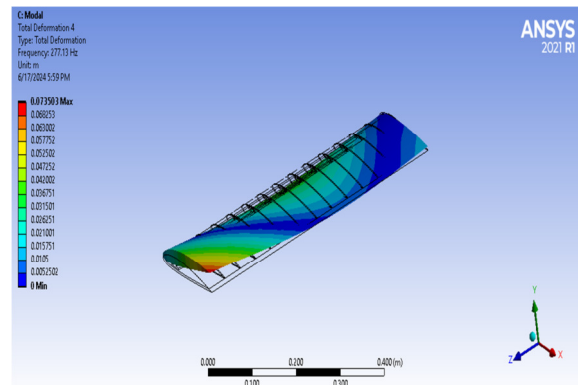

Fig. 9. Wing deformation at mode 4.

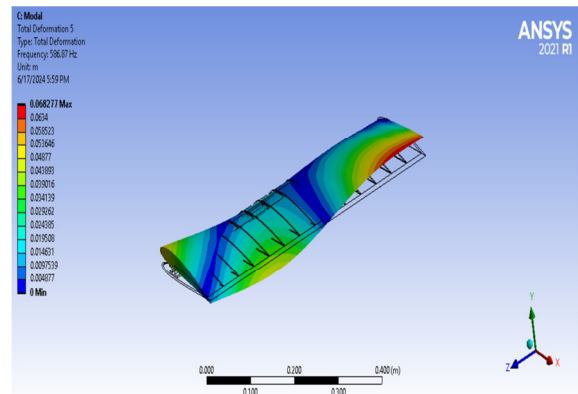

Fig. 10. Wing deformation at mode 5.

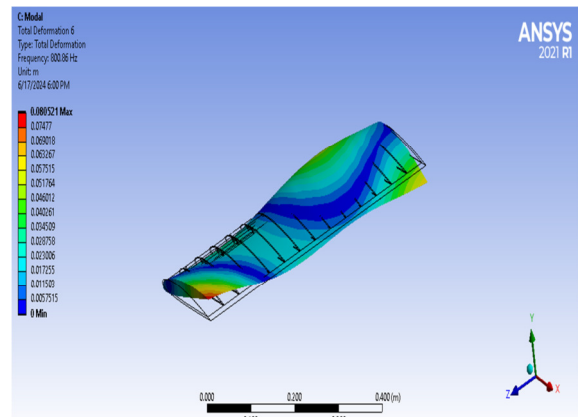

Fig. 11. Wing deformation at mode 6.

TABLE I. NATURAL FREQUENCY, MAXIMUM DEFORMATION, AND MODE SHAPES

Mode No.	Frequency, 13 ribs (Hz)	Max. deformation, 13 ribs (mm)	Frequency, 18 ribs (Hz)	Max. deformation, 18 ribs (mm)
1	36.698	42.685	36.699	42.136
2	68.454	40.133	68.711	39.528
3	203.14	57.223	203.8	56.737
4	277.13	73.503	276.71	72.792

Increasing the rib count from 13 to 18 strengthens and absorbs vibrations, reducing oscillations. This method reduces

vibrations by changing mass stiffness and organization within the structure. Extra ribs provide contact points and support, distributing vibrational energy more evenly and decreasing its concentration. Thus, the structure becomes more stable and stiffer, reducing vibration. Adding ribs may reduce vibration by providing:

1. Increased rigidity: More ribs increase structural rigidity, minimizing bending and vibration.
2. Better damping: Extra ribs absorb and spread vibrational energy, reducing vibration.
3. Improved weight distribution: More ribs distribute weight more evenly, reducing stress concentrations that may cause vibration.
4. Frequency shift: Adding ribs may change the structure's intrinsic frequencies, pushing them away from resonance frequencies that cause vibration.

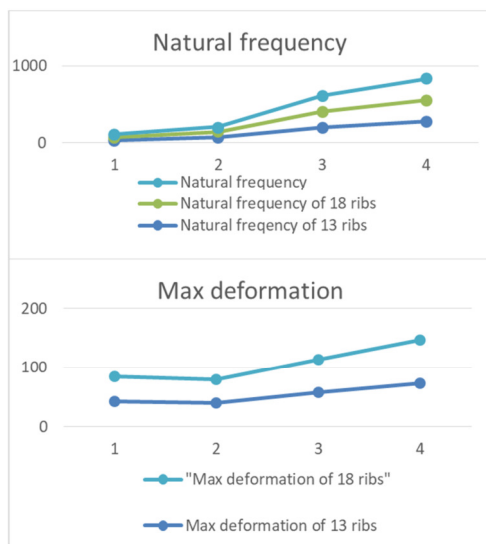

Fig. 12. Natural frequency, max deformation.

B. Frequency Response

Figure 13 provides the frequency response of an aircraft wing based on various AoAs and speeds. Figure 13 shows two noticeable peaks in the frequency. These peaks indicate the natural frequencies of maximum wing deformation. Usually, larger deformations result from higher AOAs and speeds. For example, the line illustrating 15 AOA and 17 m/s speed shows higher distortion than that of 5 AOA and 9 m/s. The first peak occurs at about 70 Hz and the second peak at about 175 Hz. Knowing these frequencies helps one to understand resonance situations. Aircraft designers have to ensure operational frequencies do not coincide with natural frequencies to avoid too significant wing deformation and possibly structural failure. The materials chosen for the wings have to withstand the maximum expected distortion. Structural reinforcements could be needed at important points. While performance has to be kept, ideal AOA and speed combinations should minimize distortion. This graph helps one to find safe operational limitations for different flying conditions.

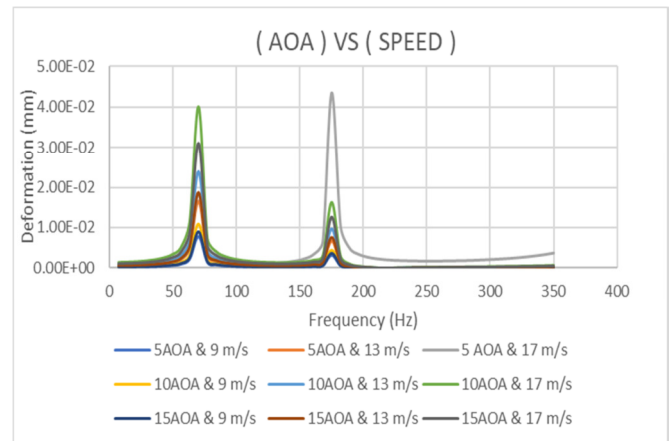

Fig. 13. Frequency response, max deformation in various AOAs and speeds.

III. CONCLUSIONS

The results of the Computational Fluid Dynamics (CFD) analysis demonstrate that the pressure on the upper surface of the wing along the wing is smaller than that on the wing lower surface by about $2.622e2 \text{ N/mm}^2$. The pressure on the lower surface is approximately $9.294e1 \text{ N/mm}^2$. This finding provides evidence that the theory of lift generation is correct. An examination of the pre-stressed modal analysis demonstrates the connection between the stress, the deformation, and the vibrational modes that are associated with it. It has been discovered that the maximum deformation of 80.521 mm is connected to the modal frequency of 800.86 Hz, which consequently defines the design frequency of the wing construction. The fundamental natural frequency of the wing structure for the deformation of 42.685 mm is 36.698 Hz.

REFERENCES

- [1] S. A. H. Mohsan, M. A. Khan, F. Noor, I. Ullah, and M. H. Alsharif, "Towards the Unmanned Aerial Vehicles (UAVs): A Comprehensive Review," *Drones*, vol. 6, no. 147, Jun. 2022, <https://doi.org/10.3390/drones6060147>.
- [2] V. Dragan, "A Numerical Proof of Concept for Thermal Flow Control," *Engineering, Technology & Applied Science Research*, vol. 7, no. 1, pp. 1387–1390, Feb. 2017, <https://doi.org/10.48084/etasr.974>.
- [3] "Navier-Stokes Equations," NASA. <https://www.grc.nasa.gov/www/k-12/airplane/nseqs.html>.
- [4] D. Bhatia, Y. Zhao, D. Yadav, and J. Wang, "Drag Reduction Using Biomimetic Sharkskin Denticles," *Engineering, Technology & Applied Science Research*, vol. 11, no. 5, pp. 7665–7672, Oct. 2021, <https://doi.org/10.48084/etasr.4347>.
- [5] B. H. Tongue, *Principles of Vibration*, 2nd ed. Oxford, NY, USA: Oxford University Press, 2001.
- [6] N. Zimmermann and P. H. Wang, "A review of failure modes and fracture analysis of aircraft composite materials," in *Engineering Failure Analysis*, vol. 115, West Lafayette, IN, USA, 2020.
- [7] S. Gialanella and A. Malandrucolo, "Alloys for Aircraft Structures," in *Aerospace Alloys*, Cham, Switzerland: Springer, 2020, pp. 41–127.
- [8] E. N. Jacobs, K. E. Ward, and R. M. Pinkerton, "The characteristics of 78 related airfoil sections from tests in the variable-density wind tunnel," NACA Technical Report PB-177874, Jan. 1933, <https://ntrs.nasa.gov/citations/19930091108>.
- [9] M. T. Nguyen, N. V. Nguyen, and T. M. Pham, "Aerodynamic Analysis of Aircraft Wing," *VNU University of Engineering and Technology*, vol. 31, no. 2, pp. 68–75, May 2015.

- [10] S. Eftekhari and A. Sh. M. Al-Obaidi, "Investigation of a NACA0012 Finite Wing Aerodynamics at Low Reynold's Numbers and 0° to 90° Angle of Attack," *Journal of Aerospace Technology and Management*, vol. 11, no. 1, Mar. 2019, <https://doi.org/10.5028/jatm.v11.1023>.
- [11] I. Gorban and O. Lebid, "Numerical Modeling of the Wing Aerodynamics at Angle-of-Attack at Low Reynolds Numbers: Fundamentals, Problems and Challenges," in *Modern Mathematics and Mechanics*, 2019, pp. 159–179.
- [12] N. Kuntoji and V. V. Kuppast, "Study of Aircraft Wing with Emphasis on Vibration Characteristics," *International Journal of Engineering Research and Applications*, vol. 07, no. 4, pp. 01–08, Apr. 2017, <https://doi.org/10.9790/9622-0704040108>.
- [13] N. A. Ismail, M. U. Kaisan, M. B. Balogun, M. B. Abdullahi, F. T. Faru, and I. U. Ibrahim, "Effect of Angle of Attack on Lift, Drag, Pitching Moment and Pressure Distribution of NACA 4415 Wing," *ATBU Journal of Science, Technology and Education*, vol. 8, no. 1, pp. 31–44, Feb. 2020.